

E C A H O

European Conference of  
Arab Horse Organizations

**ECAHO**

**Түргүлүктү 'Pleasure  
Riding Classes**

## DEFINITION of „Pleasure“

In pleasure classes horses are shown in all gaits on both hands on the rail in a group. Competitors can pass each other without coming too close.

Good pleasure horses have a brisk, animated stride that allows them to comfortably move forward with grace and elegance. Their gaits result from a balanced, cadenced motion, that emanates from impulsion created by the hindquarters. Their natural conformation allows them to carry the head and neck in a natural position.

Pleasure horses should be calm, willingly, confident and responsive and perform all the gaits straight and correctly. They should be balanced in all aspects and give the appearance they enjoy their job. They should be **a pleasure to ride**. It is the judge's task to find the horse in a competition coming closest to the ideal of the specific class.

*From the ECAHO Green Book:*

**“Judging is not absolute. It requires observation and evaluation. Good judging depends upon correct observance of the points and the selection of the best pleasure horses in that class.**

Judging is based on certain criteria and rules. However, in judging performance everything is relative. Each horse must be judged against the performance of the others in the class. All faults should be considered according to their severity and the depth of the competition. Good judging depends upon correct observation and the selection of the best horses for the purpose of the class. The best horse, performing the most correctly should be the winner.”

## DESCRIPTION OF GAITS

Gaits	Good	Minor faults	Major faults	Elimination
<b>Walk</b>	4-beat gait, ground-covering, flat-footed, balanced, straight, confident, relaxed	slow, irregular speed, too fast, disinterested, not attentive	nervous, jogging, not walking, pulling	
<b>Jog</b>	2-beat-diagonal-gait, balanced, good motion, consistent, collected, steady, smooth	too slow/fast	not performing a 2-beat jog, hard/rough riding, break of gait, poll too high/low	
<b>Trot</b>	2-beat-diagonal-gait, medium speed with moderate collection, balanced, good motion, consistent, steady, smooth, strength from hindquarters, show lift/elevation of horse's front	too slow/fast	not performing a 2-beat jog, hard/rough riding, break of gait, pulling, poll too high/low	
<b>Extended Jog</b>	easy riding, balanced, consistent, good motion, effortlessly lengthening of strides	inconsistent speed, loss of cadence or balance or rhythm, looks forced or artificial	break of gait, pulling, hard/rough riding, no increase of speed, no lengthening of strides	
<b>Strong Trot</b>	balanced, consistent, good motion, effortlessly lengthening of strides, powerful, reaching	inconsistent speed, loss of cadence or balance or rhythm, looks forced or artificial,	break of gait, pulling, hard/rough riding, no increase of speed, no lengthening of strides, too much/high knee action, unnatural head carriage	

<b>Lope/Canter</b>	3-beat-gait, balanced, good motion, consistent, steady, smooth, easy riding, straight, correct left/right lead, natural head carriage, natural length of strides	too slow/fast, not straight	wrong lead, break of gait, pulling, not performing a 3-beat lope, hard/rough riding, poll too high/low	
<b>Hand Gallop</b>	3-beat-gait, see Lope/Canter, further engagement of hindquarters, lengthening of strides without losing frame or cadence, strong, but controlled and balanced, elegant in motion, easily be able to come to a smooth stop at any time	too slow/fast, not straight	wrong lead, break of gait, pulling, not performing a 3-beat lope, hard/rough riding, poll too high/low	
<b>Back</b>	2-beat-gait, proper flexion, responsive, straight, no hesitation	hesitant, not straight	throwing head, gaping, pulling not backing, heavy in shoulder	
<b>General</b>	smooth, steady, easy riding, balanced, good attitude/manner, smooth transitions	over/under flexing, sour ears, tail switching, inconsistent speed, out of balance	throwing head, gaping, break of gaits, schooling, disobedience (kicking, bucking, rearing, biting) improper gaits, poll too high/low	two hands on reins or fingers between closed reins or more than one finger between split reins, changing of hand/reins, double bridle & snaffle reins in one hand, illegal equipment, additional maneuvers, pulling, fall of horse/rider, blood, lameness, touching the horse/saddle

**COMMON in all PLEASURE CLASSES**

- Pleasure classes are rail classes shown as a group competition.
- Novice/Advanced/Master classes possible
- The judge calls for the gaits.
- For clear identification it is necessary to wear the entry number on both sides on the blanket!
- Competitors enter the ring in counterclockwise direction
- No posting allowed except in Hunter pleasure!
- Spurs are allowed according to the specific rules.
- Light rein contact can be maintained at all gaits.
- Passing other competitors is allowed on the 2nd track without disturbing the others
- Reverse at the walk/jog/trot possible as to be called for by the judge
- Always to be reversed to the inside of the arena away from the rail
- Not allowed: circles, stops, diagonals = additional maneuvers lead to disqualification
- Other equipment than allowed leads to disqualification
- Judges are allowed to check on the equipment!
- Logos, etc. according to FEI rules
- No martingales, tiedowns, bandages or boots

*Notes:*

---

---

---

---

---

---

---

---

---

---

---

---

---

---

---

---

---

---

---

---

---

---

---

---

---

## CLASSIC PLEASURE



### Rider's & horse's equipment

- Equipment for dressage classes according to FEI
- Equipment should fit the class (novice, advanced, masters)
- Spurs, whips or crops optional

### Qualifying Gaits

The horse should give the impression of being a pleasure to ride and show a mannerly attitude. All gaits must be performed straight and willingly with ease, cadence and balance. Transitions should be smooth.

- Competitors enter the ring in **counterclockwise** direction in **Normal Trot**
- **Walk**: a four-beat gait, brisk, flat-footed with good reach
- **Normal Trot**: a two-beat gait, performed at medium speed with moderate collection, mannerly, cadenced, balanced and free-moving.
- **Strong Trot**: a bit faster and stronger than normal trot but with a visible difference to it; performed with a lengthened stride, powerful and reaching; in harmony with its own natural stride; show moderate collection without too much action in the front legs
- **Canter**: a three-beat gait, smooth, correct, straight with moderate collection on both hands, not hurried
- **Hand Gallop**: visible difference to canter; performed with a lengthened stride, powerful and ground covering but under control at any time; correct and straight on both hands; in harmony with its own natural stride; extreme speed will be penalized
- **Back**: straight and fluent, without any resistance, to be performed on the center line

### Judging

- Judging starts at the moment the competitor enters the arena.
- All gaits are judged equally.
- The rider itself will not be judged but, of course, influences the performance of the horse.
- Disqualifications according to FEI: fall off the horse, riding additional maneuvers, wrong/not allowed equipment, blood, lameness
- Penalized if wrong gaits are shown, kicking, bucking, biting, rearing, bolting, pulling, disturbing other competitors

## WESTERN PLEASURE



### Rider's equipment

- Western style according to the rules

### Horse's equipment

- Snaffles/Bits must be used according to the rules.
- A change of reins during the competition is not allowed.
- Pleasure bridle/saddle/seat and attire

### Qualifying Gaits

The horse should give the impression of being a pleasure to ride and show a mannerly attitude. All gaits must be performed straight and willingly with ease, cadence and balance. Transitions should be smooth.

- Competitors enter the ring in **counterclockwise** direction at the **Walk**
- a natural, flat-footed **Walk**, a comfortable, smooth **Jog** and a flowing, smooth **Lope** are required
- **Extended Jog and Canter** may be asked in advanced/master classes
- **Back**: straight and fluent, without any resistance, to be performed on the center line
- Quiet standstill is a must!

### Judging

- Judging starts at the moment the competitor enters the arena.
- All gaits are judged equally.
- The horses are judged on manners, performance, suitability as a pleasure horse, quality and conformation
- The rider itself will not be judged but, of course, influences the performance of the horse.
- Disqualifications according to FEI: fall off the horse, riding additional maneuvers, wrong/not allowed equipment, blood, lameness
- Penalized if wrong gaits shown, kicking, bucking, biting, rearing, bolting, pulling, disturbing other competitors

## TRADITIONAL ARABIAN RIDING CLASS

(Mounted Native Costumes)



### Equipment

Safety is of utmost importance in tack and attire!

### Rider's equipment

- Native Bedouin type costume including a flowing cape or coat, pantaloons, head dress, scarf or sash
- No whips or crops allowed!
- No objects may be carried other than reins (no weapons, no animals)

### Horse's equipment

- Bits, bridles and saddles: either classic or western
- All bits may be used with two hands except romal reins.
- A change of reins during the competition is not allowed.
- Blanket has to cover the croup
- Breastcollar mandatory

### Qualifying Gaits

The horse should give the impression of being a pleasure to ride and show a mannerly attitude. All gaits must be performed straight and willingly with ease, cadence and balance. Transitions should be smooth.

- Competitors enter the ring in **counterclockwise** direction at the **Canter**
- a ground-covering **Walk**, a correct, straight and smooth **Lope** and **Hand Gallop** are required
- **No Jog/Trot** demanded
- **No Backing** demanded!
- Line-up head-to tail in two lines (left and right of the center line) leaving gaps for judging the attire
- Quiet standstill is a must!



**Judging**

- Judging starts at the moment the competitor enters the arena.
- All gaits are judged equally.
- 75 % on manners, performance, suitability, quality and conformation
- 25 % on equipment
- The rider itself will not be judged but, of course, influences the performance of the horse.
- Disqualifications according to FEI: fall off the horse, riding additional maneuvers, wrong/not allowed equipment, blood, lameness
- Penalized if wrong gaits shown, kicking, bucking, biting, rearing, bolting, pulling, disturbing other competitors

## LADIES SIDE SADDLE



### General

- Western and Classic divided or together in one class (depending on the number of entries)
- Safety is of utmost importance in tack and attire!

### Rider's equipment

- either Classic or Western style
- Spurs, whips or crops optional
- Incomplete clothing might be penalized.

#### Classic:

- English side saddle (period) attire, hat or dark top hat with net, boots, gloves, hair net, no apron

#### Western:

- a long-sleeved blouse/shirt, a western or divided skirt, no apron, hat, western boots

### Horse's equipment

- Bits must be used according to the rules.
- A change of reins during the competition is not allowed.

#### Classic:

- Hunter or Dressage bridle/saddle including balance girth/seat and attire
- Classic Pleasure gaits are to be shown

#### Western:

- Pleasure bridle/saddle including back cinch/seat and attire
- Western Pleasure gaits are to be shown

### Qualifying Gaits

The horse should give the impression of being a pleasure to ride and show a mannerly attitude. All gaits must be performed straight and willingly with ease, cadence and balance. Transitions should be smooth.

- Competitors enter the ring in **counterclockwise** direction at the **Trot (classic)** or **Jog (western)**
- a ground-covering **Walk**, a comfortable **Jog/Trot** and a flowing, smooth **Lope/Canter** are required
- **No Strong Trot and Hand Gallop required**
- **Back:** straight and fluent, without any resistance, to be performed on the center line
- Quiet standstill is a must!

### Judging

- Judging starts at the moment the competitor enters the arena.
- All gaits are judged equally.
- 85 % on manners, performance, suitability as a side saddle mount, quality and conformation
- 15 % on equipment
- The rider itself will not be judged but, of course, influences the performance of the horse.
- Disqualifications according to FEI: fall off the horse, riding additional maneuvers, wrong/not allowed equipment, blood, lameness
- Penalized if wrong gaits shown, kicking, bucking, biting, rearing, bolting, pulling, disturbing other competitors

## HUNTER PLEASURE



### Rider's & horse's equipment

- Equipment for hunter under saddle classes according to the rules
- Horses are shown under saddle, no jumps
- **Posting in trot and two-position seat in lope have to be shown**
- Equipment should fit the class (novice, advanced, masters)
- Spurs, whips or crops optional

### Qualifying Gaits

The horse should give the impression of being a pleasure to ride and show a mannerly attitude. All gaits must be performed straight and willingly with ease, cadence and balance. Transitions should be smooth.

- Competitors enter the ring in **counterclockwise** direction in **Normal Trot**
- **Walk**: a four-beat gait, brisk, flat-footed with good reach
- **Normal Trot**: a two-beat gait, performed at medium speed with moderate collection, mannerly, cadenced, balanced and free-moving.
- **Canter**: a three-beat gait, smooth, correct, straight with moderate collection on both hands, not hurried
- **Hand Gallop**: visible difference to canter; performed with a lengthened stride, powerful and ground covering but under control at any time; correct and straight on both hands; in harmony with its own natural stride; extreme speed will be penalized
- **Back**: straight and fluent, without any resistance, to be performed on the center line

### Judging

- Judging starts at the moment the competitor enters the arena.
- All gaits are judged equally.
- The rider itself will not be judged but, of course, influences the performance of the horse.
- Disqualifications according to FEI: fall off the horse, riding additional maneuvers, wrong/not allowed equipment, blood, lameness
- Penalized if wrong gaits are shown, kicking, bucking, biting, rearing, bolting, pulling, disturbing other competitors

# WESTERN BITS

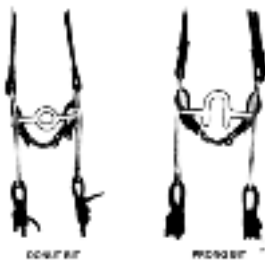
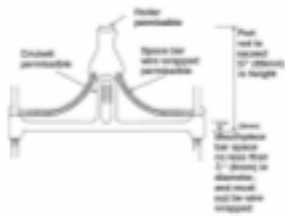
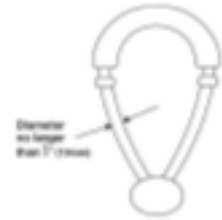
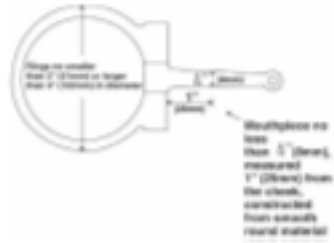
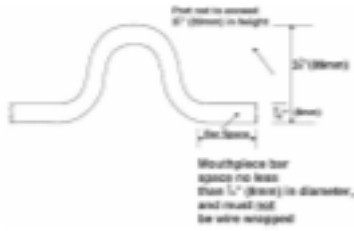

illegal bits

# ENGLISH SNAFFLES & BITS



*Example:*

**Various double bridle bits**

**Examples:**

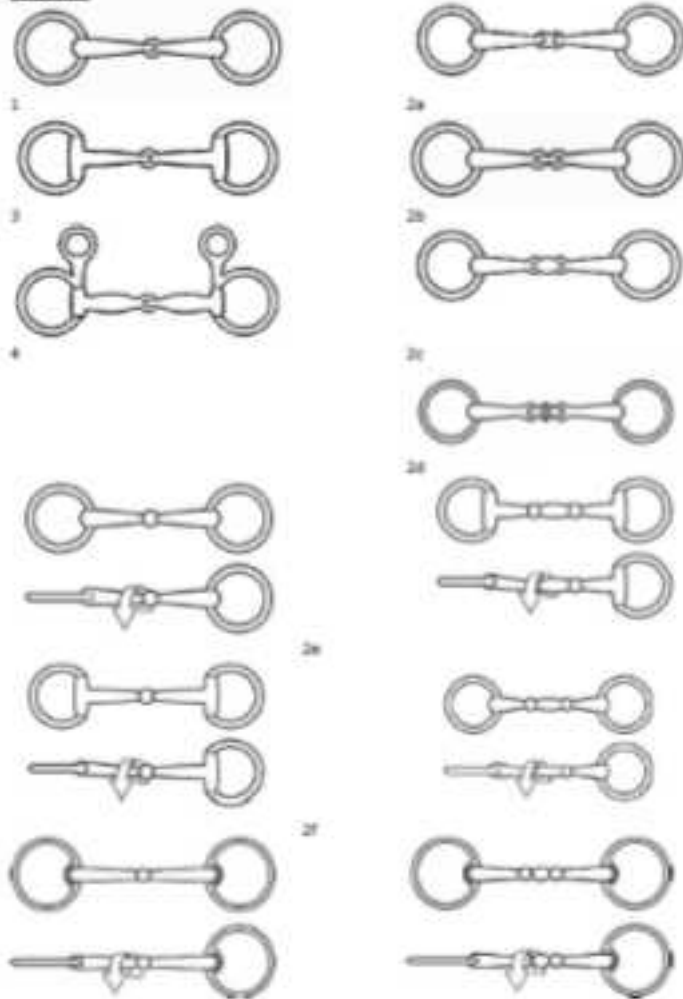

**Curb:**

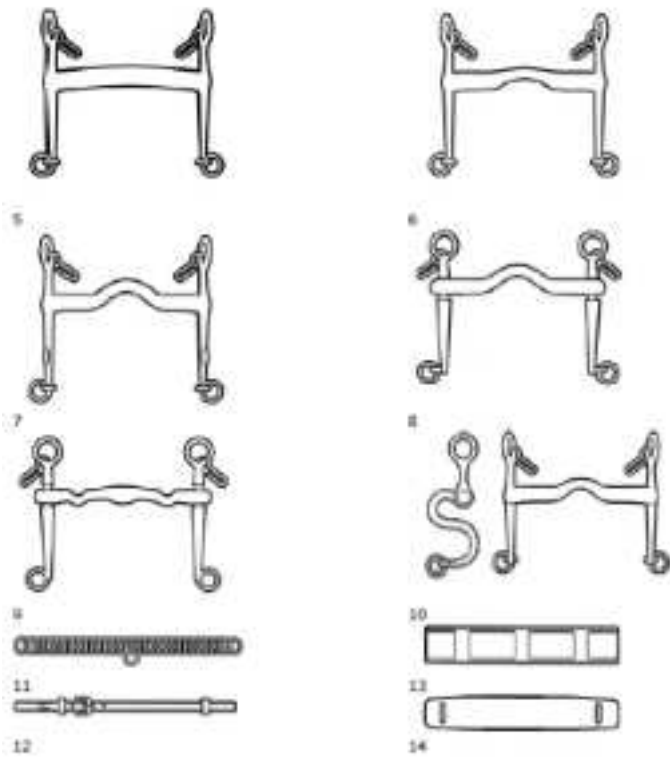

**Various snaffle bridle bits**

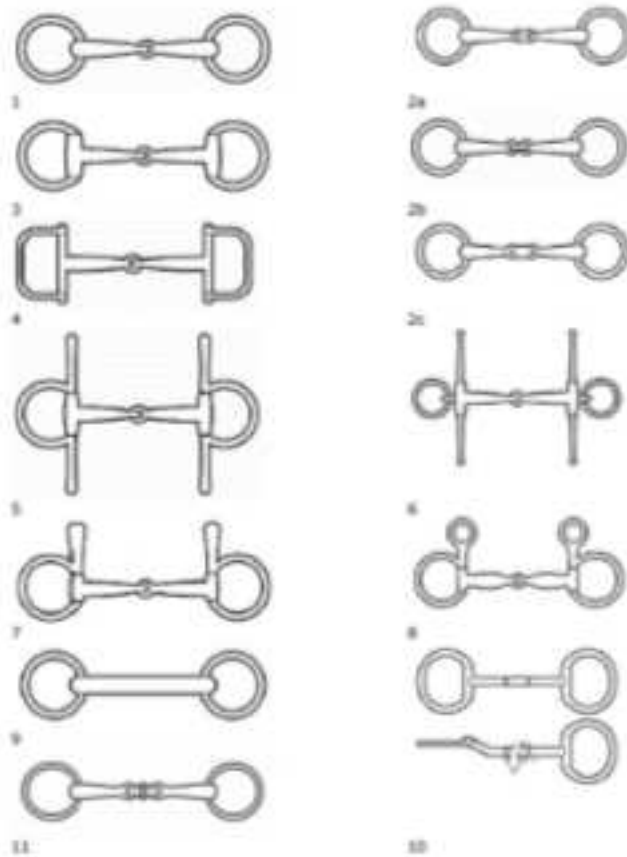

Rotary bit

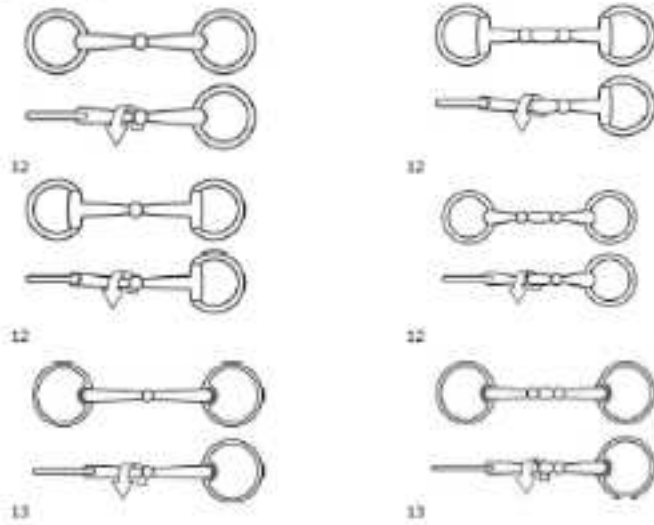

Examples for Side Saddles:

